

# OPERATION MANUAL



## RK-2001UA

SOLID FUEL FIRED  
BOILER TEMPERATURE CONTROLLER

## 1. Application

RK-2001UA controller is a device designed for temperature control of solid fuel fired boilers. The temperature of the boiler is kept on level set by user, by controlling the speed of the pressure fan. The controller monitors temperature of water in the boiler, displays it on the display, and controls circulating pump. To enable more precise temperature control of heated rooms, the controller is equipped with input for room thermostat.

The controller is equipped with additional multipurpose output which allows connecting mixing valve, alarm signal or additional gas or oil boiler.

## 2. Connection

Before turning on the device by master switch, connect controller, pressure fan and circulating pump power cords to appropriate sockets in the rear of the controller. Temperature sensor should be placed in measurement hole in the boiler. Picture 2. shows diagram of electrical connection of the device.

**WARNING!** Before plugging the device to the power source check if it is properly grounded and if the screws of the connector are properly screwed.

**CAUTION!** The maximum total power of devices connected to the controller mustn't exceed 450W.

Not used power outs of the controller may remain unconnected.

## 3. Operation

After turning the device on, all the elements of the display are lit for a while to check if they are working properly. The controller, when power appears, returns to its last state before turning off or power loss.

Front of the device (Pic. 1) consist of:

- 1 - Master switch
- 2 - Display, indicating boiler temperature and parameters
- 3 - Room thermostat indicator
- 4 - Boiler thermostat knob
- 5 - Circulating pump indicator
- 6 - STOP/choose parameters/erase alarms button
- 7 - START/choose parameters button
- 8 - Start programming in service mode/confirm settings button



Picture 1. Front of the device

Basic operation of the device is done by setting desired temperature with boiler thermostat knob, other functions are realized according to parameters programmed in service mode. While changing boiler temperature settings with the knob, the change is displayed on the display for a few seconds (for example [C180]) and this value means the temperature, which the controller will be trying to achieve. You can check this value by pressing OK button. After pressing START button, the fan starts to work and the control process begins. STOP button stops the fan, for example allowing to add fuel to the boiler.

If the controller isn't in service mode, the display shows water temperature of the boiler and the last sign on the display defines mode, which controller currently is in:

- for example: [180-] - STOP mode
- [180F]- WORK mode
- [180r] - keeping fire in WORK mode

#### 4. Setting up the parameters - service mode

Holding OK button for more than 3 seconds causes change to service mode, where you can view and change programmed parameters.

Service mode is indicated by flashing of the room thermostat indicator. You can look through parameters with < and > arrow buttons. After choosing desired parameter, you can switch to change mode of the parameter by pressing OK button - this mode is indicated by value of the parameter flashing.

Change of the parameter is possible by pressing - or + buttons. You can confirm new settings by OK button and after that there is possible to choose another parameter (with < > buttons). If you want to quit service mode, choose [End] option with < and > arrow buttons and press OK; or wait 1 minute. The device will exit service mode and will start to indicate boiler temperature.

Table 1. Service parameter's list

Display	Parameter	Min	Max	Step	Factory default
Π100	fan power or max fan power when Nr 1	50	100	10%	100
Πr 1	automatic fan speed control	-,0	10	1	1
Πn 5	fan work time	-,5	60	1s	5
Πu 6	fan pause time	1	99	1min	6
P144	circulating pump launch temperature	85	160	1°F	144
Ph 4	circulating pump launch hysteresis	2	20	1°F	4
Pc 2	pause time between circ. pump 30 sec. work periods	-,1	99	1min	2
L150	min boiler temperature	85	150	5°F	150
H195	max boiler temperature	175	195	5°F	195
h 10	boiler temperature hysteresis	2	20	1°F	10
A210	boiler overheating temperature	195	210	1°F	210
Fd60	no-fuel testing time during fuel firing start	-,1	99-4h	1min	60
Fb30	no-fuel testing time during work mode	-,1	99-4h	1min	30
Ar 0	additional output: 0-FUEL, 1-ALARM, 2-MIX	0	2	1	0
Prod	return to factory settings after pressing OK				
outP	test of circ. pump output (press OK to launch the test)	outP	out1		
outΠ	test of fan output (press OK to launch the test)	outΠ	out2		
outr	test of additional output (press OK to launch the test)	outr	out3		
End	quit service mode after pressing OK				

In the table above, the first column represents example display indications, in the next columns there are: parameter description, minimal amount, maximum amount allowed to set, step of the parameter during the setup, factory defaults, to which you can return by choosing [Prod] option.

#### 4.1. Pressure fan work parameters

Fan power [Π100] - this value defines power of the fan. When "Πr"parameter is set to "0-10" this is the maximum power of the fan which can be achieved during automatic fan control.

Automatic fan speed control [Πr 1] - it is on, when this parameter is set to "0-10" and causes automatic fan speed decrease when temperature of water in the boiler reaches desired temperature. If this parameter is set to "-", the fan automatic smooth speed control is disabled and the fan can work with power set by "Π" parameter. Setting parameter value in range from 0 to 10 means time in minutes of the smooth fan speed increase from 40% to value of "Π" for smooth boiler start.

Fan work time [Πn 5] - time of turning the fan on for a while, to remove accumulated gases. Setting the parameter to "-" turns this function off.

This function can be active in WORK mode.

Fan pause time [Plu 6] - time between fan work periods

#### 4.2. Circulating pump parameters

Circulating pump launch temperature [P144] - temperature of water in the boiler, which causes start of the circulating pump. Circulating pump works independently from the control process and is launched additionally in case of boiler overheat.

Circulating pump launch hysteresis [Ph 4] - this parameter defines what value should temperature decrease by, below circulating pump launch temperature, to turn the pump off.

Pause time between circulating pump 30 second work periods [Pc 2]- in STOP mode or when room thermostat circuit is open, the circulating pump is launched for 30 seconds, to mix water in heating circulation. This parameter defines time between launches of the pump.

Setting the parameter to "-" turns this function off.

#### 4.3. Boiler work temperature setting

Minimal boiler temperature [L150] - minimal temperature, which you can set with the boiler thermostat knob.

Maximum boiler temperature [H195] - maximum temperature, which you can set with the boiler thermostat knob.

Boiler temperature hysteresis [h 10] - this parameter defines what value should temperature of water in the boiler decrease by, below temperature set with the thermostat knob, to turn the pressure fan on.

#### 4.4. Boiler overheating protection

Boiler overheating temperature [A210] - value, exceeding which causes permanent turn off of the pressure fan and launch of the circulating pump, to prevent boiler overheating. Overheating mode is indicated by boiler overheating indicator and by displaying error [E 2] on the display. It can be turned off by pressing STOP button, but only when temperature decreases below boiler overheating temperature.

Pressure fan turning off occurs also in case of damage of the boiler temperature sensor, which is displayed on the display by error [E 1].

STB - the controller has also additional protection from overheating, which is independent from the processor, . In case of temperature increase over 200°F, the control process is turned off by turning the fan off and launching

the circulating pump. The fan and the pump are joined to the control process again, when temperature reaches 190°F.

STB circuit enables more precise boiler work control and reduces overheating possibility.

#### 4.5. No fuel

No-fuel testing time during fuel firing start [Fd60] - after switching to WORK mode, if water temperature doesn't reach temperature set with the thermostat in programmed time, the control process will be turned off and the display will show the message: [FUEL].

You can return to previous mode by pressing STOP button.

No-fuel testing time during work mode [Fb30] - in WORK mode, if temperature of water in the boiler decreases below temperature set with the thermostat, by hysteresis value, and don't reach temperature set with the thermostat in programmed time, the control process will be turned off and the display will show the message: [FUEL]. You can cancel the alarm by pressing STOP button.

4.6. Additional output work mode [Ar 0] - the controller has been equipped with a multipurpose output that can work in one of following modes:

- mode [Ar 0] - output may control the oil or gas boiler if such boiler exists in the heating circuit. After switching the controller on with the main power switch the additional boiler is turned off and it turns on again when there is no fuel in the solid fuel boiler. This function is useful in heating systems where a solid fuel boiler is used to cut the heating costs. After erasing the no fuel alarm by pressing STOP button the additional boiler is again turned off and the controller works again

- mode [Ar 1] - output may control the additional alarm signaling system. Boiler temperature sensor malfunction, overheating and no fuel alarm will turn on the alarm

- mode [Ar 2] - output may control the mixing valve servo-motor. Controlling the mixing valve requires room thermostat to be present. Mixing valve is being opened and closed depending on the room thermostat input. Additionally, mixing valve is opened in case of overheating or boiler temperature sensor malfunction.

CAUTION. Equipment should be connected to additional output using UM-1 module. Connection schemes are shown on picture 3.

#### 4.7. Testing of device's outputs

To make checking the controller work easier, it is possible to test output circuits which control the fan and the pump, and the circuit which controls additional boiler. This function is available in service mode, only if the control process is off, i.e. the controller was in STOP mode before switching to service mode. By choosing [outP] on the display and pressing OK button you can turn on the circulating pump for a while, by choosing [outΠ] and pressing OK you can turn on the pressure fan and by choosing [outr] and pressing OK you can turn the additional boiler, the alarm signaling system or the mixing valve servo-motor on (if the additional module is connected).

#### 4.8. Factory defaults

You can return to standard settings, set by the producer, by choosing [Prod] option in service mode and pressing OK button. After activating this function, the device sets each parameter showed in the table to default.

#### 4.9. Exiting service mode

By choosing [End ] option on the display and pressing OK button you can quit service mode. The device also quits service mode, when no buttons are pressed for 1 minute.

#### 5. Additional functions

To improve comfort in heated rooms, the device is equipped with input allowing to connect any kind of room thermostat with contact output. When temperature in the room is below desired temperature, the circulating pump is turned on and the room thermostat indicator is lit.

It means that the boiler should keep temperature set by the room thermostat. After reaching desired temperature in the room, the room thermostat indicator turns off, the circulating pump is turned off and the boiler switches to mode, in which it's keeping minimal temperature.

**CAUTION.** In case of not having room thermostat in the system, the room thermostat input contacts must be short-circuited.

#### 6. Device failures

The controller is constantly testing if its internal circuits and temperature sensor are working correctly. After detection of fault, it stops the pressure fan, turns on the circulating pump and shows proper error message on the

display. In case of failure please turn off the controller, plug the circulating pump to the power source, bypassing the controller, ensure appropriate fuel firing in the boiler and contact the service.

When [E 1] error appears on the display, it means fault (short-circuit) in the boiler sensor circuit or temperature below 32°F. [E 2] is displayed if boiler overheats. [E 3] error means fault and overheating at the same time. Appearing of [E 1] error on the display without ability to cancel it by pressing STOP button, in spite of temperature below 190°F, may mean permanent damage of boiler temperature sensor (e.g. if the boiler overheated above 300°F).

### 7. Device removal

In case of need to remove the controller from the system:

- turn the master switch off
- disconnect the power of the boiler
- remove the controller from the slot in the boiler
- disconnect all connectors with cords from the controller

### 8. Specifications

Voltage:	115V ± 10% / 60Hz
Power consumption:	<4VA
Temperature measurement range:	32 - 210°F ±2°F
Boiler temperature adjustment range:	85 - 195°F ±2°F
Programmable boiler overheating protection:	195 - 210°F ±2°F
Hardware boiler overheating protection:	>200°F ±2°F
Circulating pump launch temperature:	85 - 160°F ±2°F
Fan out:	total max 2A/115V
Dimensions:	80 x 170 x 100 mm

Producer: P.W. KEY [www.pwkey.com](http://www.pwkey.com)



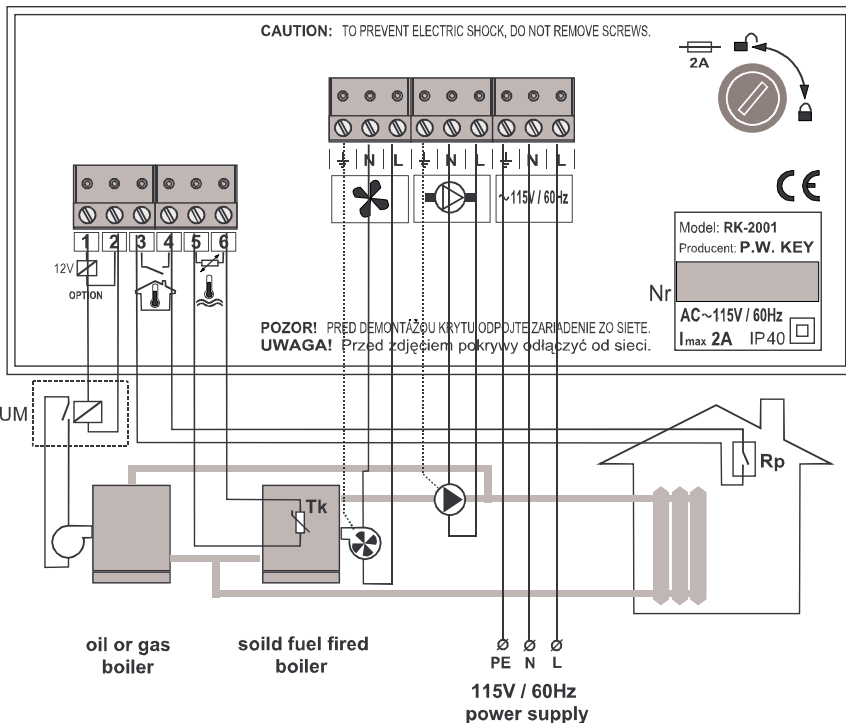

Picture 2. RK-2001UA connection scheme

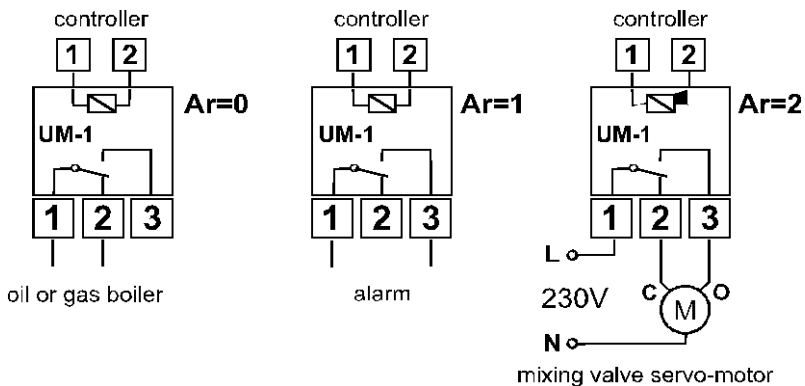

Picture 3. UM-1 modul connection scheme.

## 9. Notes

Display	Parameter	User
Π100	fan power or max fan power when Nr 1	
Πr 1	automatic fan speed control	
Πn 5	fan work time	
Πu 6	fan pause time	
P144	circulating pump launch temperature	
Ph 4	circulating pump launch hysteresis	
Pc 2	pause time between circ. pump 30 sec. work periods	
L150	min boiler temperature	
H195	max boiler temperature	
h 10	boiler temperature hysteresis	
A210	boiler overheating temperature	
Fd60	no-fuel testing time during fuel firing start	
Fb30	no-fuel testing time during work mode	
Ar 0	additional output: 0-FUEL, 1-ALARM, 2-MIX	

Economically Sensible, Environmentally Friendly, Ecologically Responsible



**Eco Heat Sales**

Leading the way to responsible renewable and efficient heating comfort

**Gene Knight, CEO**

545 Morley Potsdam Road  
Canton, NY 13617  
Phone: 315-386-2878 Fax: 315-386-3009  
Email: [info@ecoheatonline.com](mailto:info@ecoheatonline.com) [www.ecoheatonline.com](http://www.ecoheatonline.com)